Table of Contents

Electronic Transmission Control

Subject	Page
Adaptive Features	38
Driver Influenced Features	39
Environmentally Influenced Features	40
CAN Bus Communication	42
Diagnosis and Troubleshooting	46
Establishing a Diagnostic Plan	47
Fault Codes	48
Identification Page	49
Diagnostic Program	50
Test Modules	51
Diagnostic Tips	52
Information Resources	53
TCM Coding and Programming	54
Transmission Fluid Information	56
Transmission Fluid Checking Procedures	57
Transmission Fluid Application	58
Transmission Service	59
Transmission Tools	60
Review Questions	66

Adaptive Features (AGS)

AGS features were introduced in 1994 with the A5S560Z transmission. AGS control consists of adaptive features that will modify transmission operation according to various factors. AGS operation can be influenced by two major functional groups:

- Driver influenced features (influenced by throttle and kickdown input)
- Environmental influences (such as road conditions - icy, traffic etc.)

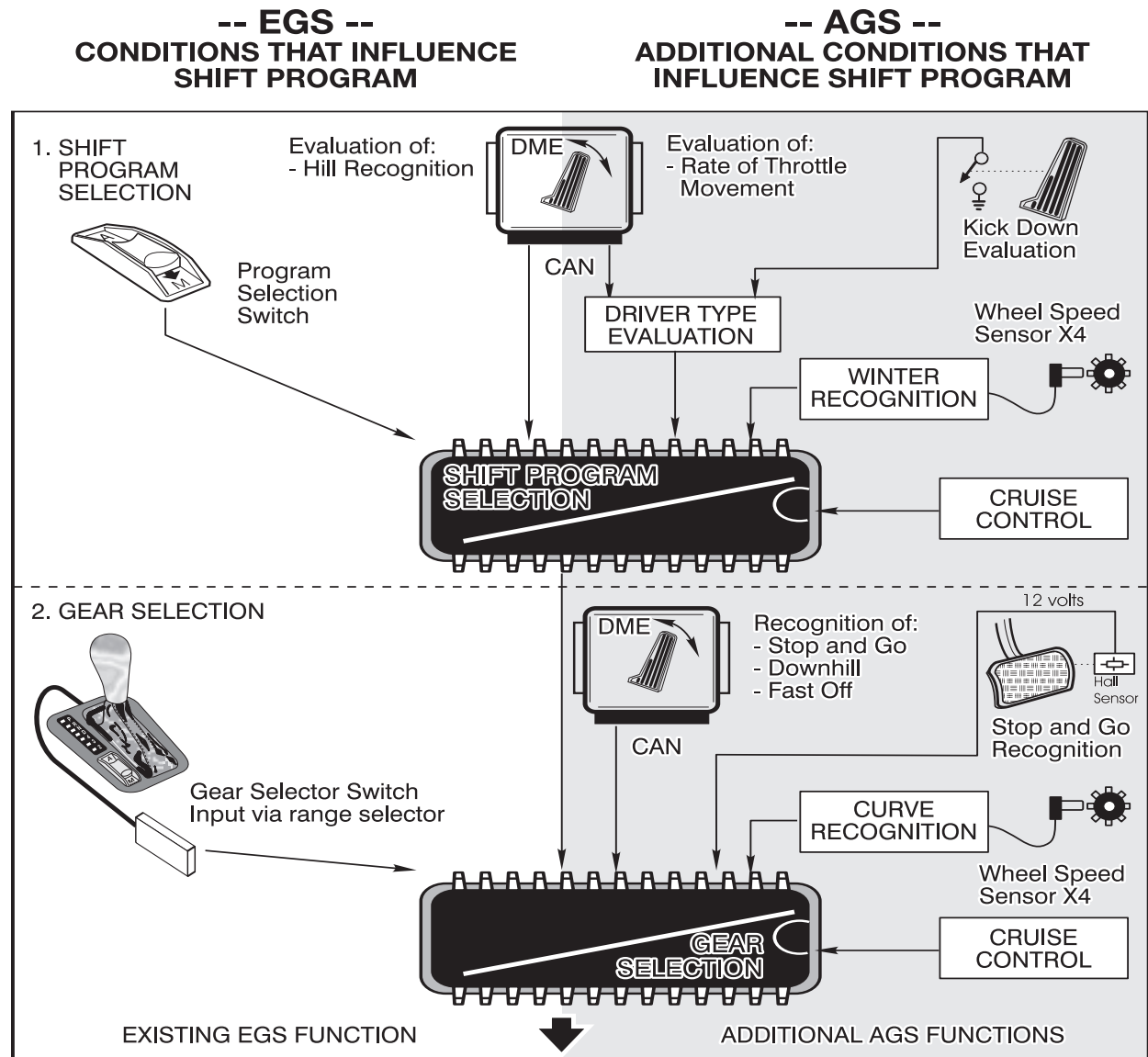

The driving program selection is not adapted on a long term basis - nor is it stored in the control module memory when the ignition is switched off. It continually changes as the driver of the vehicle changes driving habits.

Driver influenced features of AGS

The adaptive drive program is based primarily on throttle input. The throttle information comes from the ECM (DME) via the CAN bus. The TCM continuously monitors the throttle input for:

- The current throttle position
- The rate of change in pedal movement
- The number of acceleration requests
- The number of kickdown requests

Drive away Evaluation

The AGS system selects the appropriate shift program based on the amount of acceleration that occurs during takeoff. When driving away under full throttle the transmission will shift from XE to E.

Kick Fast Feature

Based on these inputs, the AGS will select one three different driving programs as follows:

- Extreme Economy - Shift points are a low speeds for maximum comfort and economy
- Economy - The shift points are raised for more performance with economy as priority
- Sport - The shift points are higher to take advantage of full engine performance.

Under full throttle acceleration at high speed, single gear downshifts are possible. A two gear downshift is possible if the accelerator pedal is moved quickly to kick-down. The Extreme Sport program was eliminated as part of the kick-fast feature.

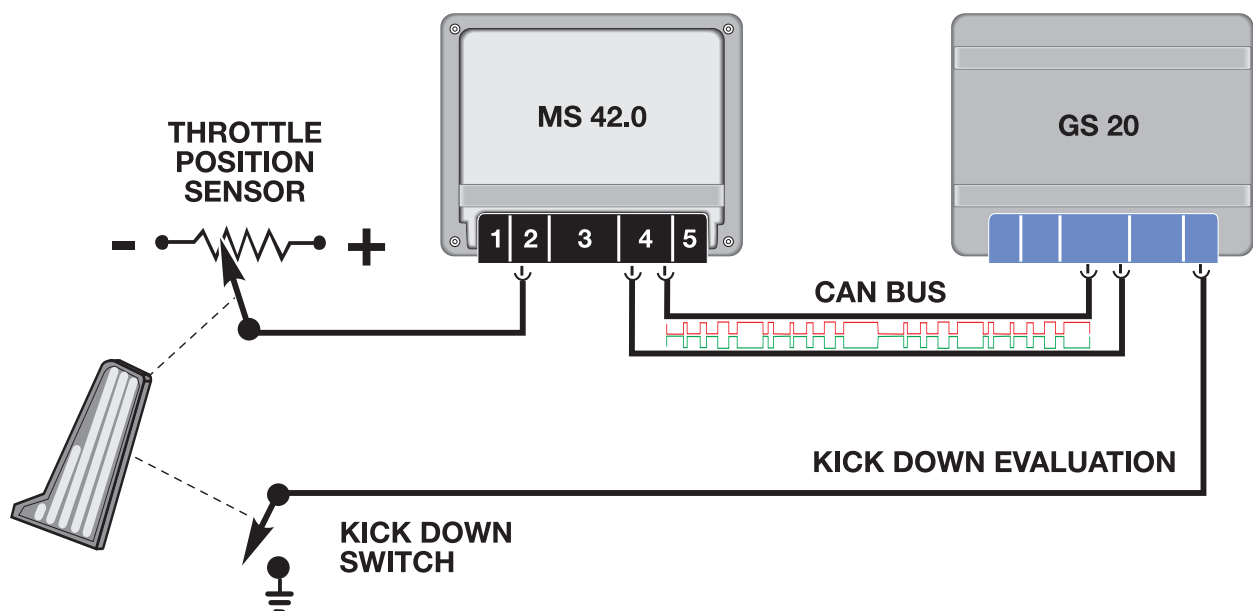

Environmentally influenced AGS features

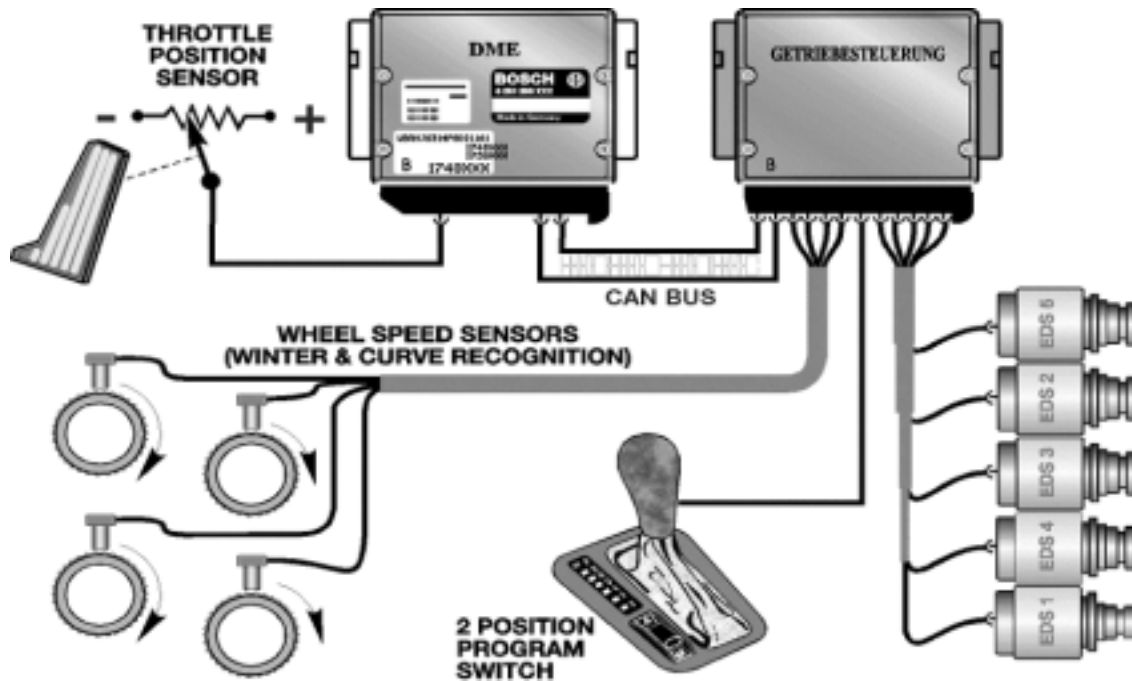

STOP and GO

The feature is activated by defined sequence of shifts which are as follows:

- Upshift from first to second - followed by a downshift from second to first - followed by another upshift from first to second. This is then followed by the vehicle coming to a complete stop.

After this sequence occurs, the transmission will stay in second gear. The AGS control has recognized stop and go driving and this function will prevent excessive shifting during heavy conditions. The second gear start will be cancelled when:

- The vehicle speed exceeds 40 MPH
- The throttle pedal is pressed more than 90%
- The range selector is moved to Park, Neutral, Reverse or Sport (4,3 or 2)
- The vehicle is in Sport Mode

Winter Drive Program

This feature is activated when the TCM detects slippage at the rear wheels by comparing front and rear wheel speed signals. When slippage is detected by the TCM, the transmission will start in second gear and the shift points will be lowered. This will reduce torque to the rear wheels allowing improved driveability and traction on slippery roads.

Hill Recognition Program

There are two hill recognition programs, one for Uphill and one for Downhill. The TCM will activate this feature when it receives a high engine load signal at slower road speeds. The TCM will perceive this information as being consistent with climbing a hill. The shift points will be raised to prevent constant up and down shifting. This is referred to as the pendulum shift effect. When driving downhill, road speed will increase with minimal throttle input. The TCM will detect a downhill situation and hold the current gear to prevent an upshift when going downhill.

Curve Recognition

This feature will inhibit upshifts when the vehicle is in a curve. This is to improve stability when the vehicle is cornering at high speeds. The TCM will initiate this feature when it detects a difference between left and right (front) wheel speed signals. The difference in these signals will indicate that the vehicle is in a curve. Be aware that improper tire sizes, brands and inflation pressures can influence this feature. Always address these issues first when diagnosing delayed upshift complaints.

Cruise Control Drive program

A special cruise control shift map is selected by the TCM when cruise control is active. The TCM will prevent unwanted locking and unlocking of the torque converter clutch. Also, upshifting and downshifting will be minimized. Depending upon application, the cruise control interfaces with TCM via a single wire data link or as on vehicles with electronic throttle control, the TCM will interface with the ECM (DME).

Manually Selected "Extreme Sport" Program

This feature is activated by moving the shift lever to position 4, 3 or 2. This activates the "Extreme Sport Program" where the shift points are raised for maximum rpm and performance. On Steptronic equipped vehicles, the sport program is obtained by moving the shifter to the manual gate to initiate the "Sport Program".

Modifications to AGS features

Since the introduction of AGS features in 1994, there have been some software changes to address customer concerns. Some AGS features have been perceived by the customer as malfunctions. To correct this, some of the AGS features were modified with updated software. The AGS features previously discussed in this text reflect the updated modifications. Always refer to the latest Service Information Bulletins for more information on AGS features.

CAN Bus Communication

The CAN bus is a serial communications bus in which all connected control units can send as well as receive information. Data over the CAN bus operates at a rate of up to 1Mb/s (megabits per second).

The CAN protocol was developed by Intel and Bosch in 1988 for use in the automotive industry to provide a standardized, reliable and cost-effective communications bus to combat the increasing size of wiring harnesses.

The CAN bus was originally introduced on BMW automobiles in the 1993 E32 740i/IL as a data link between the TCM (EGS) and the ECM (DME).

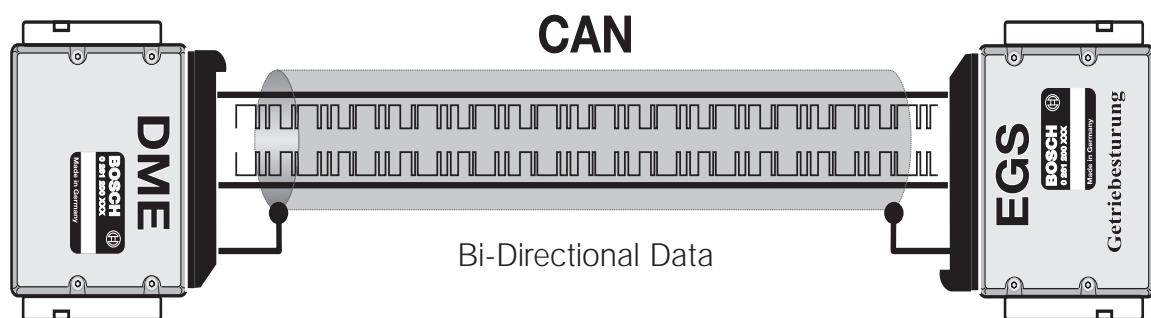

On earlier EGS systems, various signals were transmitted on individual signal wires. This reduced reliability and increased the amount of wiring needed. The CAN bus allows faster signal transmission and increased versatility. For example, the signals listed in the chart below were previously transmitted on individual wires, now these signals are all on the CAN bus. This chart represents only some of the signals on the CAN bus, there are many more signals transmitted between the TCM and ECM.

Sender	Information Item	Receiver	Signal Use
ECM	Engine Temperature	TCM	Shift Point Calculation
ECM	Engine Load (tL)	TCM	Shift Point Calculation
ECM	Engine RPM (TD)	TCM	TCC Slippage
ECM	Throttle Position (DKV)	TCM	Shift Point Calculation
ECM	A/C Compressor ON	TCM	Fine tune shift points to compensate for increased engine load.
TCM	Transmission Range	ECM	Engine Idle Speed Control
TCM	Torque Reduction Signal (ME)	ECM	Timing Retard during shifts.
TCM	TCC Lockup Status	ECM	Engine Timing Map adjustment.

CAN Bus Topology

The CAN bus consists of two twisted copper wires. Each wire contains an opposing signal with the exact same information (CAN-High, CAN-Low). The opposing signals transmitted through the twisted wire serve to suppress any electrical interference. Early CAN bus wiring included a grounded shield around the two wires, later vehicles discarded the shield in favor of the unshielded twisted pair wiring.

Due to the linear structure of the network, the CAN bus is available for other modules in the event of a disconnected or failed control unit. This is referred to as a “Tree” structure with each control unit occupying a branch.

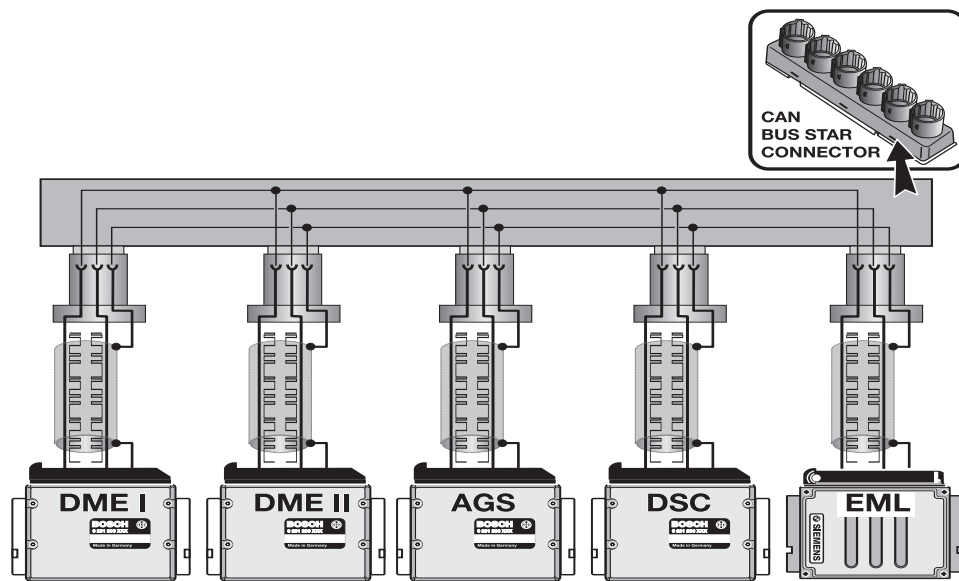

As previously mentioned, the CAN bus initially was used as a high speed communication link between the DME and AGS control units.

With the introduction of the E38 750iL (95 M.Y.), the CAN bus was expanded to include the EML and DSC control modules. The 750iL made exclusive use of the “star coupler” to link the individual CAN bus ends to a common connector.

The 1998 model year introduced new users of the CAN bus. The instrument cluster and the steering angle sensor were linked to expand the signal sharing capabilities of the vehicle.

The 1999 750iL was the last vehicle to use the shielded cable, after which the entire CAN bus went to twisted pair wiring.

Note: Always refer to the proper ETM to determine the exact wiring configuration for a specific model.

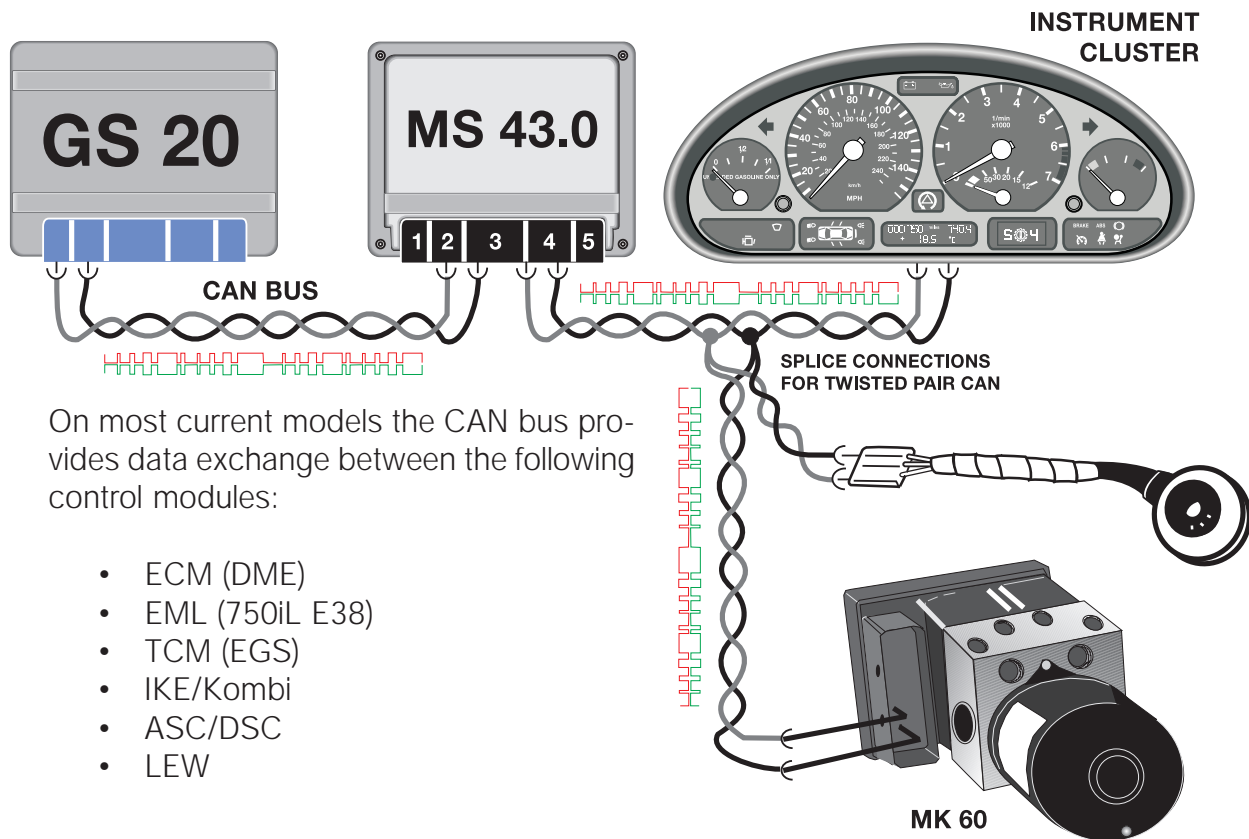

On most current models the CAN bus provides data exchange between the following control modules:

- ECM (DME)
- EML (750iL E38)
- TCM (EGS)
- IKE/Kombi
- ASC/DSC
- LEW

On models that use twisted pair, the wire color of the CAN bus is uniform throughout the vehicle with: CAN-Low GE/BR and CAN-High GE/SW or GE/RT. Shielded wiring is easily identified by the black sheath surrounding the CAN bus.

Troubleshooting the CAN Bus

The failure of communication on the CAN bus can be caused by several sources:

- Failure of the CAN bus cables.
- Failure of one of the control units attached to the CAN.
- Failure of the voltage supply or ground to individual modules.
- Interference in the CAN bus cables.

Failure of the CAN bus cables

The following faults can occur to the CAN bus wiring:

- CAN-H/L interrupted
- CAN-H/L shorted to battery voltage
- CAN-H/L shorted to ground
- CAN-H shorted to CAN-L
- Defective plug connections (damaged, corroded, or improperly crimped)

In each instance, the connected control units will store a fault due to the lack of information received over the CAN bus.

The voltage of the CAN bus is divided between the two data lines: CAN-High and CAN-Low for an average of 2.5V per line. The voltage measurement is taken from each data line to ground. Each module on the CAN contributes to this voltage.

The fact that 2.5V are present does not mean that the CAN bus is fault free, it just means that the voltage level is sufficient to support communication.

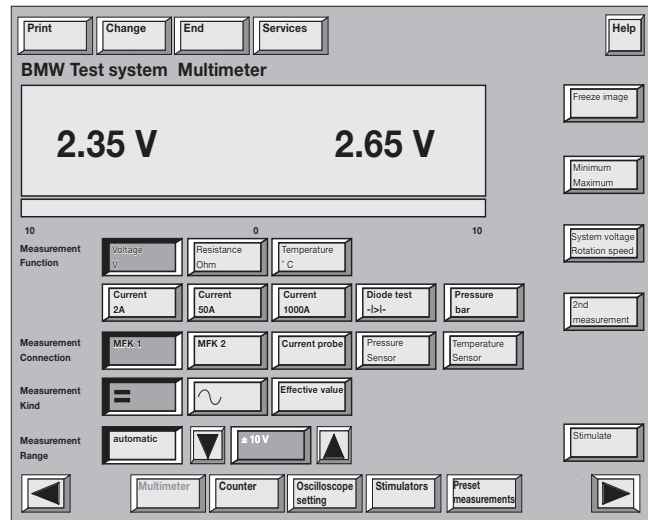

Terminal Resistors: are used in the CAN bus circuit to establish the correct impedance to ensure fault free communication. A 120 Ohm resistor is installed in **two** control units of the CAN between CAN-H and CAN-L. Because the CAN is a parallel circuit, the effective resistance of the complete circuit is 60 Ohms. On some vehicles there is a jumper wire that connects the two parallel branches together, others have an internal connection at the instrument cluster.

The resistance is measured by connecting the appropriate adapter to any of the modules on the CAN and measuring the resistance between CAN-L and CAN-H. The resistance should be 60 Ohms. The CAN bus is very stable and can continue to communicate if the resistance on the CAN bus is not completely correct; however, sporadic communication faults will occur.

The terminal resistors are located in the ASC/DSC control unit and either the instrument cluster or in the DME.

Early 750iL vehicles that used the star connector have a separate external resistor which connect CAN-H and CAN-L together.

Modules which do not have the terminal resistor can be checked by disconnecting the module and checking the resistance directly between the pins for CAN-H and CAN-L. The value at these control units should be between 10kOhms and 50kOhms.

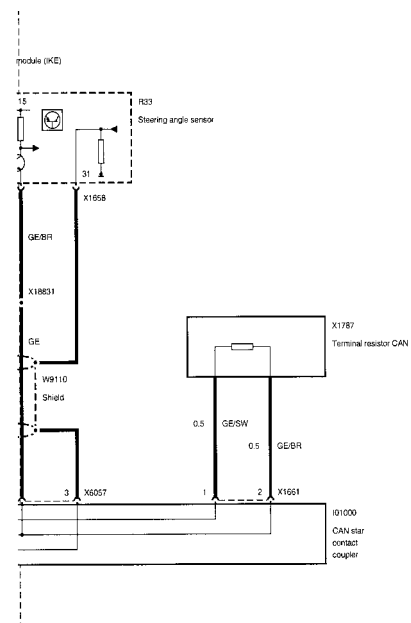

Diagnosis and Troubleshooting

Due to the cost and complexity of today's electronic transmissions, BMW recommends that the technical hotline be contacted before any repairs are performed. It is important that the technician perform some basic diagnostic procedures before contacting technical assistance. The following procedures should be followed:

- Always Verify customer complaint, make sure the complaint is not related to normal operation. (i.e. Warm Up Phase, AGS operation etc.)
- Survey Fault Memory - Perform **complete** quick test. There may be other systems that interface with EGS that could cause faults. (i.e DME, ASC/DSC, IKE/Kombi etc.)
- Print out all fault code with fault conditions. Also print out copy of Identification page and diagnostic report.
- CHECK TO SEE IF THERE ARE ANY SERVICE BULLETINS THAT APPLY TO YOUR SPECIFIC COMPLAINT. THIS INCLUDES THE SERVICE ROUNDTABLE.
- Ensure that battery voltage is sufficient. Battery voltage must be greater than 12.5 with ignition switched off. Check battery connections for tightness and condition.
- Check ground connections. (chassis to engine, grounds to bulkhead and shock tower.)
- Check over vehicle to look for transmission leaks, physical damage, loose connections etc.
- If necessary, check fluid level and condition using DISplus or GT-1.
- Check to see if any aftermarket or performance components have been installed that could effect transmission operation. (DME or EGS software as well as any engine modifications).
- Check repair history to see if there were any recent repairs that could effect the proper operation of the transmission (i.e. Engine replacement with damaged dowel pin etc.).
- Check DCS for any open campaigns or recalls pertaining to drivetrain.
- Check and record chassis number, production date and transmission serial # before contacting technical assistance.

Establishing a Diagnostic Plan

Once all of the pre-diagnostic criteria has been satisfied, a logical diagnostic plan should be followed. A logical, well organized diagnostic plan will help avoid improper diagnosis, unnecessary parts replacement and lost diagnostic time. A technician's goal should be to satisfy the customer by "Fixing it the first time, on time, every time". The productivity of the technician can also be improved by following a logical, common-sense approach to problem solving. The following steps are recommended to form a diagnostic plan:

- **Verify the Customer Complaint** - This step is the most important, but also the most overlooked. The focus should always be on the exact customer concern. Make sure that the customer complaint is not a misunderstanding of proper vehicle operation. This step can avoid unnecessary diagnosis and lost time. If the customer concern is not exactly identified, any subsequent repairs can not be verified as being effective. This is the most common cause of "comeback" repairs. Communication between the customer to advisor and the advisor to technician must be clear. Vague or misunderstood customer complaints are often improperly diagnosed. Also make sure that the conditions under which the concern has occurred are duplicated. For example: If the customer is complaining about a shifting concern after a cold start, then the vehicle should be road tested under those conditions.
- **Analyze the Problem** - Once the complaint has been verified, then all available resources should be used to find the "root cause" of the complaint. Start out by checking Service Information Bulletins, DCS messages, and Service Roundtable information. Use the DISplus or GT-1 to access the diagnostic program and perform Diagnostic Test Modules where applicable. Electrical Troubleshooting Manuals (ETM's) should also be used when needed.
- **Isolate the Problem** - Now, the problem can be narrowed down into the final steps of diagnosis. Using proper tools and procedures, the technician can "Isolate" by using the process of elimination and common sense. Having a working knowledge of BMW systems is helpful in this area. When applicable, use all available BMW special tools and equipment. Perform all necessary electrical checks such as Voltage Drop, resistance measurements etc.
- **Repair the Problem** - Once the concern has been correctly identified, perform all necessary repairs as per BMW guidelines. Make sure all repairs are properly documented to comply with warranty policies and procedures.
- **Verify the Repair** - Make sure the customer concern has been rectified. Road test the vehicle under the same conditions whenever possible. Failure to complete this step properly is almost a guaranteed comeback. Repeat repair attempts are costly to the BMW Center and the BMW Service Technician.

REMEMBER - Fix it the first time, On Time, Every time.

Fault Codes

When diagnosing transmission fault codes, always print out the fault code(s) and the fault conditions. When referring to the fault code itself, be aware that there are actually 3 formats for the fault code. The fault code breakdown is as follows:

Fault Code Example:

Fault Code (050) 32 Gear Monitoring 1 (PO731)

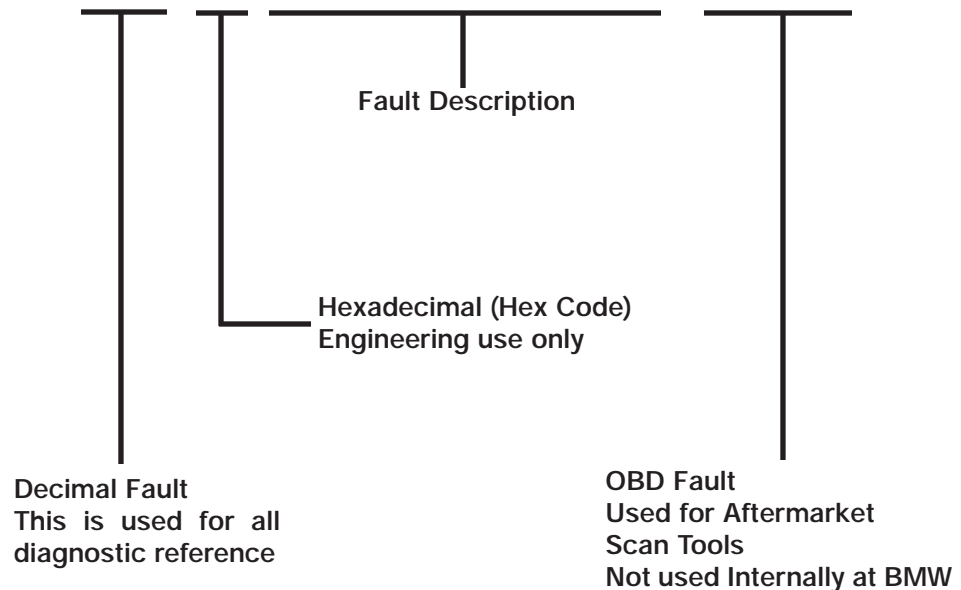

When referring to the "Fault Code" during diagnosis always use the fault that is in Decimal Format. The Decimal fault is referred to in all reference material such as Service Information Bulletins, Test Modules and DCS messages etc. In the example above, FC 050 would be the correct choice.

Fault Conditions

When a fault code is set, it is stored with a set of environmental conditions. The environmental conditions are used to aid in pinpointing the root cause of the fault. Some of the information found in the fault conditions contain information on transmission temperature, engine speed and road speed etc. This information is also helpful when trying to duplicate the customer complaint. For example, if a customer complains about a shifting complaint when cold, check the fault conditions to verify this complaint. Remember to always print out the fault codes with the fault conditions. This information is helpful to the technician as well as technical assistance.

Identification Page

The ID page is helpful to determine the Transmission and control system used as well as the chassis number and current software version. Always print out a copy of the ID page when performing any diagnosis or programming procedures.

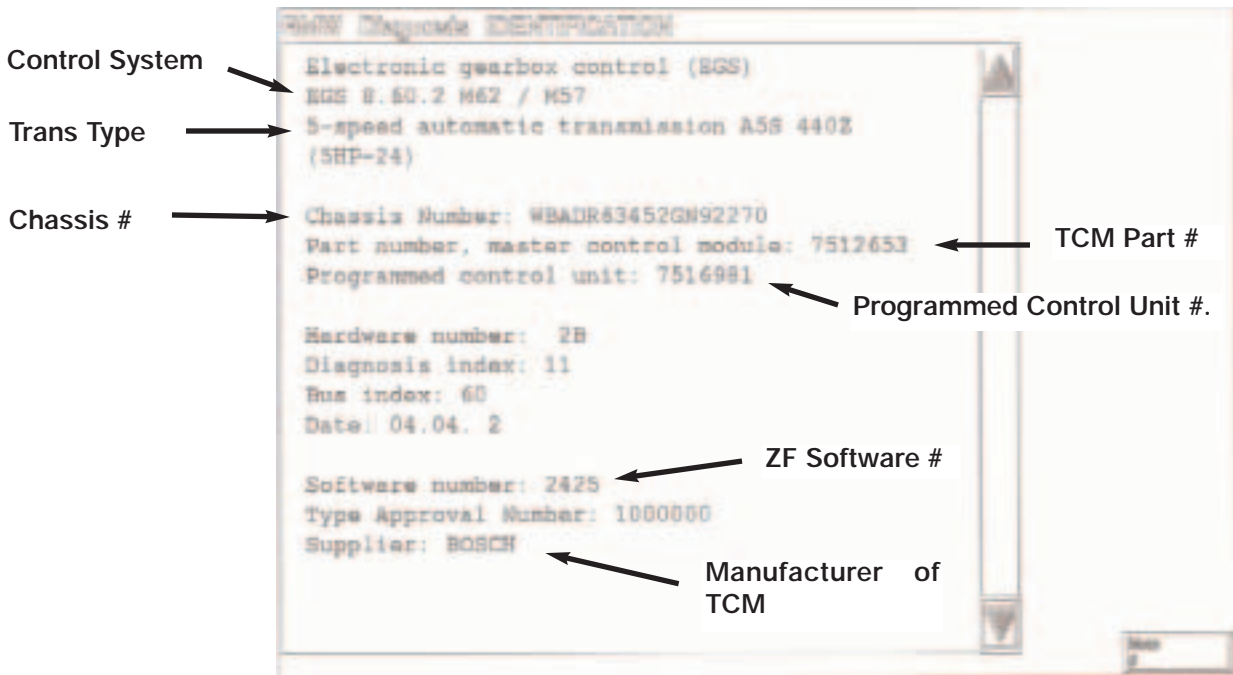

Diagnosis Program

There are two diagnostic formats (programs) used on current model BMW vehicles. The earlier diagnostic program was used on the E38 and E39. The latter diagnostic program was introduced as the "E46 Diagnostic Concept". This is used on the E46, E65 and the E52 (Z8). The E53 X5 uses a mixture of both diagnostic programs depending upon engine/transmission options. Below is an example of the earlier diagnostic program.



The diagnostic program contains the following features:

- **Fault Symptoms** - This is a symptom driven program that will lead the technician into guided diagnostics. It contains several possible fault scenarios that are common to electronic transmissions. This path is helpful when the technician is not sure where to start in his diagnostic plan.
- **Function Test** - There are no function tests for electronic transmissions.
- **Service Functions** - This is where you will find the ATF level check function. Also Test Codes can be obtained and printed out for warranty purposes. The Adaptation values can be cleared as well as printed out.
- **Expert Mode** - Expert Mode should be used when the technician has a thorough working knowledge of the system. You will find several items in expert mode: Read/Clear fault memory, Diagnosis (Status) requests, Component Activation and Test Modules.

Test Modules

Test modules are found in the diagnosis program of the DISplus and GT-1. These allow the technician to take advantage of a guided diagnostic plan. The program will direct the technician through the various steps using a “trouble tree” format. When using test modules it is important to follow the instructions exactly. Due to the complex nature of some faults, the test modules are not always conclusive. The test module is only as effective as the information provided by the technician. The technician also needs to rely on his experience and some common sense. The test modules should be used to assist the technician, not as a replacement for good diagnostic skills.

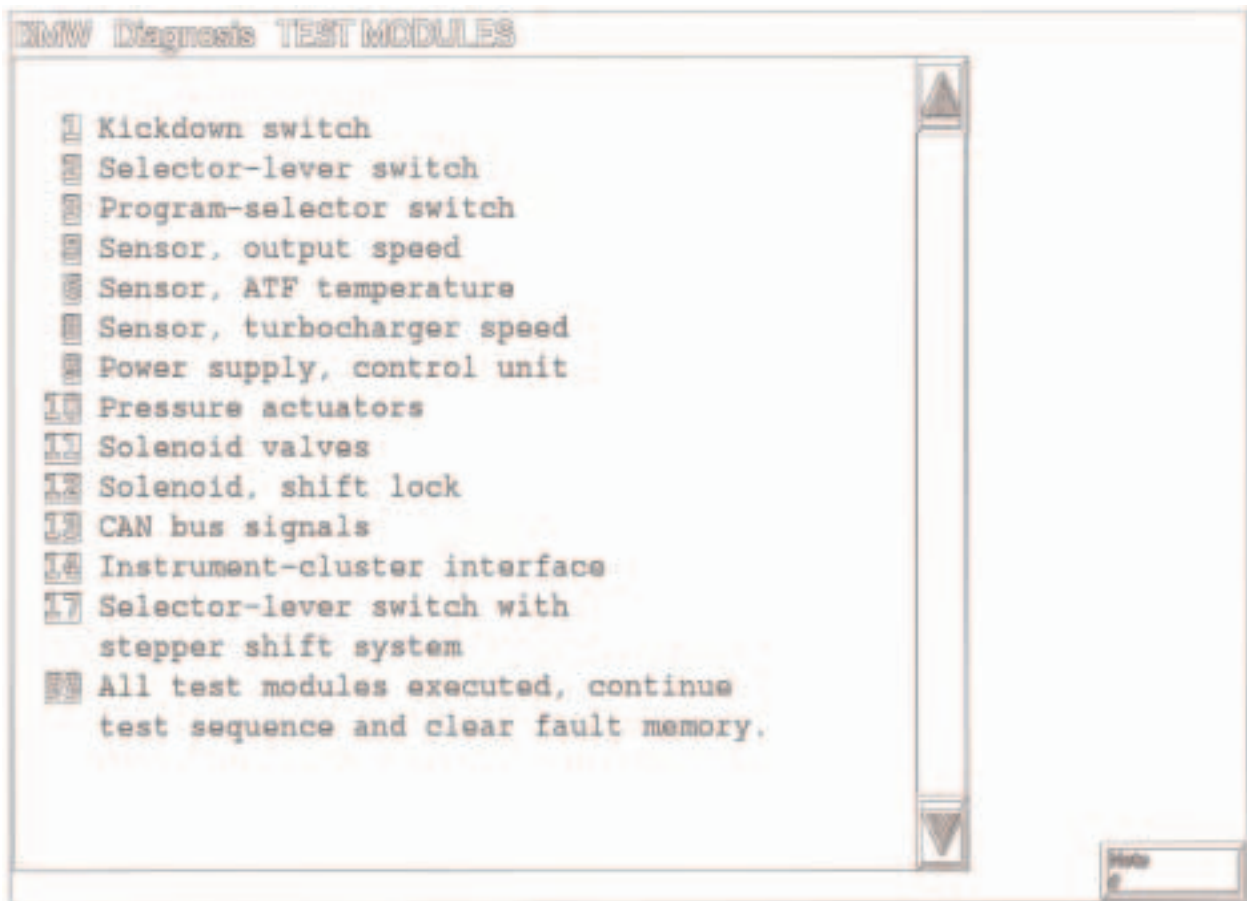

Test modules come in two formats. The one shown above is used on E38/E39 vehicles and the E53 with 4.4 and 4.6 engines. The E46, E65 and E53 (with 3.0 M54) uses the new “E46 Diagnostic Concept” which was introduced with the E46 in the 1999 model year. Regardless of the format used, the technician is still guided through a step by step procedure.

Diagnostic Tips

The following consists of some helpful hints to assist the BMW diagnostic technician. It is designed to assist the technician to form a logical path of diagnosis. These suggestions should be used in conjunction with other approved diagnostic routines. This does not exclude the technician from the responsibility to contact technical assistance. All major repairs and transmission replacement must be pre-approved by the BMW Technical Hotline. Transmission concerns can be broken down into several categories:

- **Shift Quality Complaints** - Shift Quality complaints consist of harsh up or down shifts, improper shift points and erratic shifting. These complaints could be related to electronic/software issues or hydraulic/mechanical problems. Perform quick test and check SIB's before proceeding. As with most concerns, check the transmission fluid level and condition as well.
Do not clear adaptation values unless instructed to do so by BMW Technical Hotline.
- **Delayed/No Upshifts** - Before proceeding on delayed upshift complaints, make sure you are aware of the conditions that this occurs. This could be normal operation, such as the "Warm-up Phase" program. Always check front tires for proper inflation pressures, correct size and type. Also check for uneven tire wear. Variations in front tire size from left to right can activate the AGS "Curve Recognition" feature. The TCM will interpret the difference in wheel speed signals as being a turn and suppress (or delay) upshifts.
- **Slipping** - This type of issue is usually associated with a fault code. Be sure to check the transmission fluid level and condition.
- **Noise, Vibration** - Noises and vibrations should be checked over by a good visual inspection. Look for loose transmission or engine mounts. Check the driveshaft, center bearing and flexible coupling (or constant velocity joints). Also check the lateral alignment of the driveshaft. There are several SIB's pertaining to noise and vibration.
- **No Forward or Reverse Gear** - Start by checking transmission fluid level and note the fluid condition. Inspect for leaks and external transmission damage.
- **Leaks** - When investigation transmission leaks, be sure to verify that the suspected leak is actually transmission fluid. Engine oil, hydraulic and brake fluid can be mistaken for a transmission leak. Check the transmission cooler lines, transmission cooler and transmission pan gasket. Try to locate the source of the leak. Do not make any major repairs until the technical hotline is contacted.
- **Fault Codes** - Perform COMPLETE short test (Quick test) on all vehicle systems. It is important to survey all systems in the event that a related system is causing the transmission fault. Always print out the ID Page, Fault codes and fault conditions.

Information Resources

When diagnosing transmission related concerns it is important to use all information resources available. The following information sources should be utilized at all times:

- Service Information Bulletins
- Technical Data
- ETM Electrical Troubleshooting Manual
- DCS (Dealer Communication System)
- Repair Instructions
- Tightening Torques
- Technical Training Manuals
- Special Tool Information

Technical Information System (TIS)

Most of the above information can be accessed by using the BMW TIS CD or by logging on the the BMW TIS website through www.bmwcenternet.com. The BMW TIS website contains a wealth of helpful information for the technician. The information is updated on a regular basis.

Service Roundtable

In addition to the above sources of information, the technician should be up to date on the latest edition of the BMW Service Roundtable. The roundtable will cover the most recent topics and offer some hints that will assist the technician. The Service Roundtable is broadcast live on a monthly basis via the BMW Visionwerke Network. In addition to live broadcasts, the roundtable is rebroadcast on a regular schedule during the month.

TCM Coding and Programming

As with other control modules used on BMW systems, the TCM must be programmed and/or coded for the vehicle. Over the years, these methods have varied from system to system. Refer to Service Information Bulletins for the latest coding and programming information.

Coding

Coding will assign the control unit to a particular application. Information such as differential ratio, tire size, vehicle series, engine, engine control system, w/wo AC etc. are some of the possible variants that have to be considered. Transmission control units are coded using various methods.

- **Grounding pins in wiring harness connector** - On early models equipped with the 4HP22/24 EH transmissions, the TCM was coded to the vehicle by means of grounding pins in the wiring harness connector for the TCM. By selectively grounding specific pins in the harness, the TCM was assigned to that vehicle. For Example: The TCM could be installed in a 535, 635, or a 735. This only applies to the Early E-7 Versions. (E23, E24, E28)
- **TCM ordered for Specific Application** - On some later models, the TCM was ordered for a specific vehicle application, coding was not necessary.
- **Coding performed during programming** - On systems that use a flash programmable TCM, the coding process is done during flash programming.

Programming

Programming refers to the instructions that the TCM is to follow. The TCM is programmed to apply certain shift maps according to operating conditions such as vehicle speed, engine speed, engine temperature, engine load and throttle position. This information can be entered into the TCM via an updated EPROM or through flash programming.

Flash programmable control units use a EEPROM which is Electronically Erasable. The EEPROM is also soldered into the TCM and cannot be removed or replaced. Flash programmable TCM's can be programmed up to 14 times (with a new TCM).

Note: Always clear adaptations after programming.

Note: Do not program a TCM to correct a complaint unless there is a specific SIB that covers the issue. Only program when installing a new TCM or when instructed to do so by BMW Technical Assistance. Always have the ID page available when calling for technical assistance.

Control System	Transmission	Coding	Programming	TCM Type
GS 1.26 GS 1.27 GS 1.29	4HP22 EH (Early E-7) 4HP22/24 EH (Late E-7 and E-9)	Grounding pins in Harness. (Early E-7 Only) TCM ordered for specific application. Coding not needed.	Replaceable EPROM Replaceable EPROM	35 Pin 35 Pin
GS 7.3 GS 7.32 GS 7.11 GS 8.32	A5S310Z (5HP18)	TCM ordered for specific application. Coding not needed.	Replaceable EPROM	88 Pin
GS 8.60 GS 8.60.4	A5S325Z (5HP19)	Coding done when Programmed	Flash Programming (EEPROM)	134 Pin SKE
GS 8.55 GS 8.60.2	A5S440Z (5HP24)	Coding done when programmed	Flash Programming (EEPROM)	88 Pin up to 98 (E38 M62) 134 Pin SKE from 98 to present.
GS 9.2 GS 9.22 GS 9.22.1	A5S560Z (5HP30)	TCM ordered for specific application. Coding not needed.	Replaceable EPROM	88 Pin
GS 8.60.3	A5S560Z (5HP30) (E38 M73TU)	Coding done when programmed.	Flash Programming (EEPROM)	134 Pin
GS 4.14 GS 4.16	A4S310R (THMR-1)	TCM ordered for specific application. Coding not needed.	Replaceable EPROM	55 Pin
GS 8.34	A4S270R (THMR-1)	TCM ordered for specific application. Coding not needed.	Replaceable EPROM	88 Pin
GS 20	A5S360R A5S390R	Coding done when programmed	Flash Programming (EEPROM)	134 Pin SKE

Transmission Fluid Information

Transmission Fluid (Oil)

The automatic transmission provides filtered, pressure regulated hydraulic fluid for all of the transmissions functional requirements. All BMW automatic transmissions are designed to operate with specific fluids. Use of non-approved oil will cause malfunctions and irreparable transmission damage which is not covered by BMW warranty.

The transmission fluid provides the following functions:

- Lubricates mechanical components (planetary gears, bearings etc.).
- Removes heat and transfers heat to transmission cooling system. (Heat Exchanger).
- Removes debris and contaminants to sump and filter when circulated.
- Provides a transfer of kinetic energy in the torque converter.
- Allows hydraulic operation of mechanical components (clutches, brakes) via control of the valve body.

Also, transmission fluid has various properties to prevent oxidation and breakdown from heat and friction. Each type of transmission fluid has properties specific for each transmission application.

Fluid level is crucial in the proper operation of an automatic transmission. Improper fluid levels will cause improper operation and eventually irreparable transmission damage. Improper fluid level can cause:

- A low fluid level can cause an interruption in oil flow during fast acceleration or hard braking which can cause gear shift malfunctions and noises.
- An excessively high fluid level can cause the rotating mechanical components to paddle in the oil. This produces foam which introduces air into the hydraulic system.
- A low fluid level can also cause transmission overheating causing premature transmission failure.

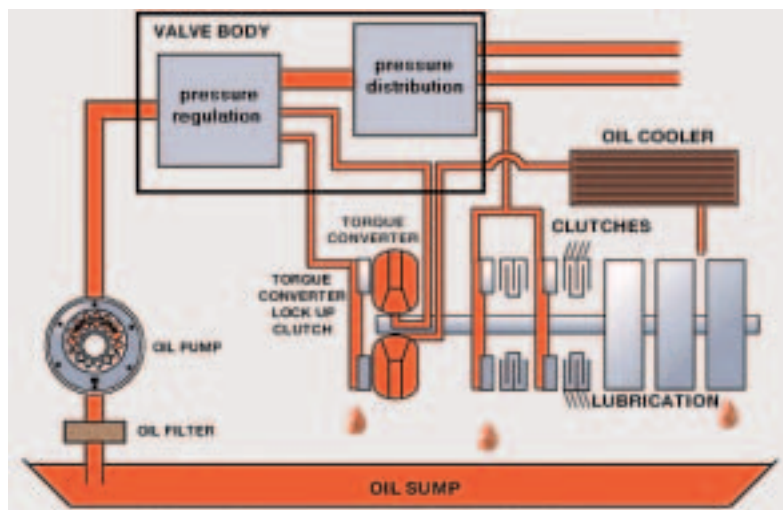

Transmission Fluid Checking Procedures

Transmission fluid checking is accomplished using the DISplus or GT-1. The DISplus or GT-1 is used to monitor transmission fluid temperature to insure the transmission is not over or under-filled. As with most other current ZF transmissions there is no dipstick, the fluid level is checked and filled at the fill plug. The location of the fill plug varies between transmissions.

Transmission fluid should be checked between 30 and 50 degrees Celsius (unless otherwise specified). Use the DISplus and/or GT-1 to determine transmission temperature. The transmission temperature information can be found in the diagnosis section under Service Functions.

Proper procedures for checking and filling transmission fluid can be found in BMW Service Information Bulletin B 24 01 98.

When checking transmission fluid, observe the following items:

- Transmission in Park
- Parking brake applied
- Engine Running
- Vehicle level
- No engine load
- Trans Temp 30-50C
- Observe correct drain plug torque
- Use correct fluid

When replacing parts on transmissions that use lifetime fluid, drain fluid into a clean container and reuse.

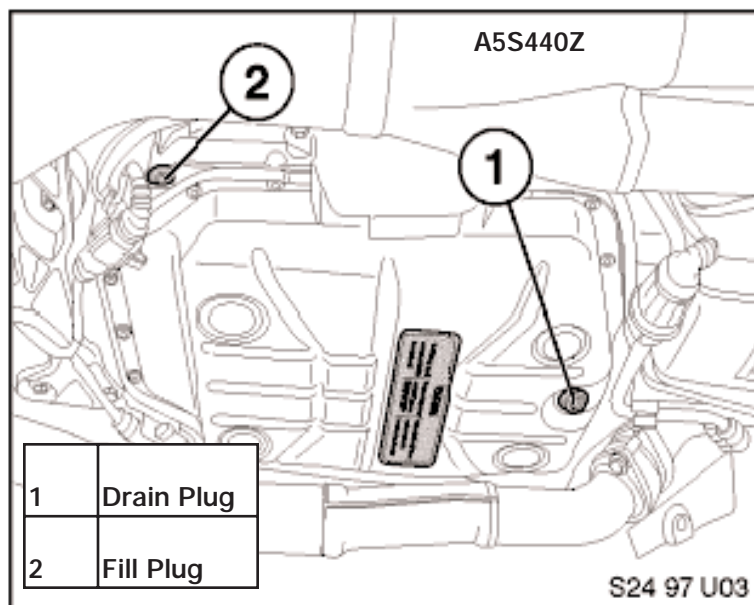

Transmission Fluid Application

There are numerous types of transmission fluid used in BMW transmissions. With the exception of the early transmissions (4HP22/24, A4S310/270R and the A5S310Z in the E34) all current BMW transmissions use "Lifetime Fill" transmission fluid. There is no maintenance required for these transmissions. It is important to use the correct fluid. Incorrect use of the transmission fluid can cause non-warrantable transmission damage.

When performing repairs on transmissions with lifetime fluid, it is important to drain the transmission fluid in to a clean container for re-use. New fluid should only be used for transmission replacement and for topping off after repairs.

Also, transmission fluid level is vital to the proper operation of the transmission. Refer to BMW Service Bulletin B 24 01 98 for proper fluid level checking procedures.

When servicing or repairing BMW automatic transmissions, refer to TIS for fluid capacities. For fluid types refer to the "Operating Fluids Manual".

Transmission	Fluid Type	BMW Part #	Container	SIB Ref.
4HP22 4HP24	Dexron III Mercon	Available Commercially (Castrol or Texaco)	N/A	
A5S310Z 530i/iT (E34)	Dexron III	Available Commercially (Castrol or Texaco)	N/A	
M3 (E36)	ESSO LT 71141	83 22 9 407 807	20 liter container	B 24 03 95
A5S325Z	ESSO LT 71141	83 22 9 407 807	20 liter container	
A5S440Z	ESSO LT 71141	83 22 9 407 807	20 liter container	
A5S560Z 740 (E32), 540 (E34) 840Ci (E31- 6/93-12/94) 740i/iL -750iL (E38)	Shell LA2634	83 22 9 407 765	5 liter container	B 24 11 92
540i (3/96-12/96) 850Ci (10/94-6/97)	ESSO LT 71141	83 22 9 407 807	20 liter container	B 24 02 94
A4S310R A4S270R (THM-R1)	Dexron III Mercon	Available Commercially (Castrol or Texaco)	N/A	
A5S360R	Texaco ETL 7045E	83 22 0 026 922	25 liter container	
A5S390R	Texaco ETL 8072B	83 22 0 024 359	25 liter container	
GA6HP26Z GA6HP32Z	Shell M-1375.4	83 22 0 142 516	20 liter container	

Transmission Service

Overview of Allowable Repairs

Currently, service of transmissions covered under warranty is limited to level I. Level I service includes electrical, minor mechanical and hydraulic repairs as well as repair manual provided service adjustments.

Part availability is limited to include the repair of the following:

- **Oil Leaks** - Radial Seals and gaskets.
- **Mechanical/Hydraulic Faults** - Torque Converter, Valve Body, parking pawl, oil pan, output shaft bearing.
- **Electrical Faults** - Solenoid Valves, pressure regulator valves, wiring harness.
- **Signal Sensing** - Turbine and Output Speed Sensors, CAN bus, Temp Sensor.

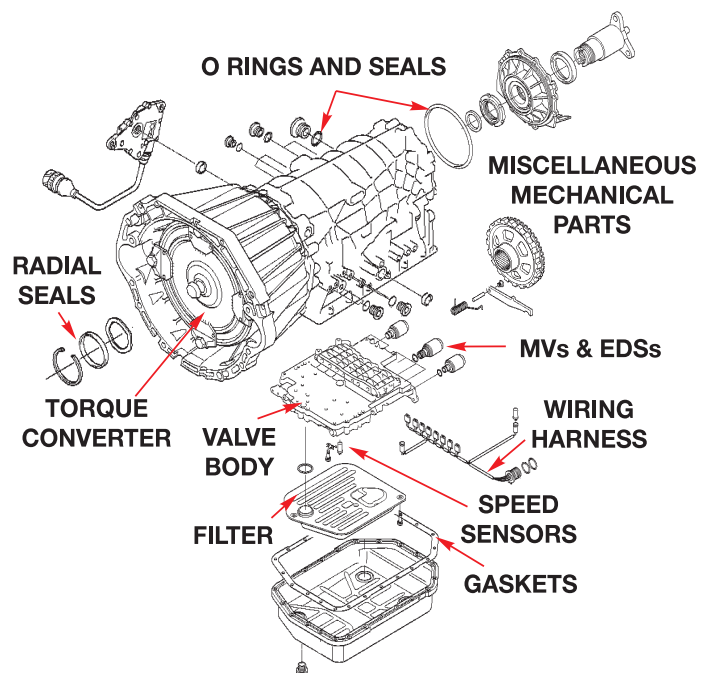

BMW Technical Hotline

Before performing any major repairs or transmission replacement, always contact the BMW Technical Hotline at 1-800-472-7222. When prompted to do so, select option 1 for the Drivetrain Group. Refer to BMW SIB B 00 04 02 for more information regarding the BMW Technical Hotline. Be prepared with all necessary information such as transmission serial number, ID page, fault codes etc. Failure to contact the technical hotline could result in the non-payment of warranty claims.

BMW Value Line Program

The Value-Line replacement transmission program provides the availability of factory certified rebuilt units at a very competitive cost. Refer to Part Bulletins in Group 24 for more information.

BMW Special Tools (Transmission)

The following pages contain information about BMW special tools, this is not an all inclusive list. This is a list of tools that would be helpful in the diagnosis and service of BMW transmissions. Always refer to the latest service information regarding special tools.

Transmission Removal and Installation

Tool # 24 1 110

This tool is used to remove the torque converter to flexplate bolts. It is a 17 mm socket with 3/8" drive. There is a magnet to help retain the bolt during installation and removal.



W24 1 110

Tool # 24 4 130

During transmission installation and removal the oil pump must be protected from damage. This tool helps keep the torque converter in place, to prevent oil pump damage due to misalignment.

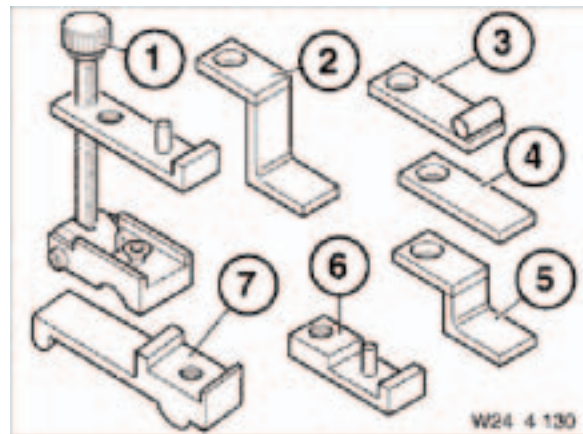

W24 4 130

Tool # 24 2 300

Used to align torque converter with flexplate during installation. Use on all BMW automatic transmissions.



W24 2 300

Transmission Adjustments

Tool # 24 2 320

3/16" socket head cap screw (hex) with 1/4 " drive. Used to adjust brake band on the THMR-1.

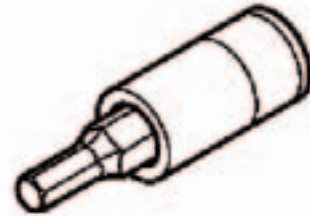

W24 2 320

Tool # 24 2 330

1/2 open end wrench used to turn lock-nut on the brake band servo when adjusting the brake band. Used only on the THMR-1 transmissions.



W24 2 330

Tool # 24 1 120

Used as guide to lock the range selector switch in "P" when installing. It is used on the A4S270R transmission. Used only for applications which have the selector switch mounted on the transmission case.



W24 1 120

Transmission Diagnostic Tools

Tool # 24 6 000

8-pin test cable used to test the transmission at the "Cannon Plug" located on transmission case. This cable is used for the 4HP22/24 EH.

Used in conjunction with 61 1 459.



Tool # 24 6 060

16 pin test cable used to test the transmission at the "Cannon Plug" located on the transmission case. This cable is used for the A5S310Z and A5S560Z.

Used in conjunction with 61 1 459.



Tool # 24 6 020

14 pin test cable used to test the transmission at the "Cannon Plug" located on the transmission case. This cable is used on the A5S310Z.

Used in conjunction with 61 1 459.



Tool # 24 6 010

8-pin test cable used to test the transmission at the "Cannon Plug" located on transmission case. This cable is used for the A4S270/310R.

Used in conjunction with 61 1 459.



Tool # 24 6 080

16-pin test cable used to test the transmission at the "Cannon Plug" located on transmission case. This cable is used for the 6HP26Z.

Used in conjunction with 61 1 459.



Tool # 24 6 070

20-pin test cable used to test the transmission at the "Cannon Plug" located on transmission case. This cable is used for the A5S360/390R.

Used in conjunction with 61 1 459.

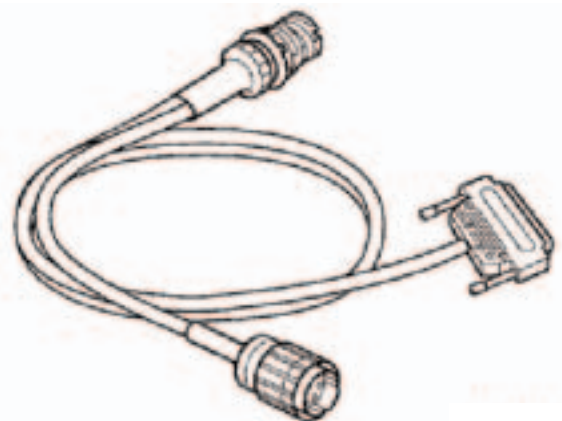

Service and Repair Tools

Tool # 24 1 170

For loosening and tightening slotted nut on output drive flange. Used on 5HP18 (A5S310Z). Use in conjunction with tool #24 1 220.

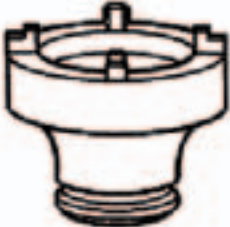

W24 1 170

Tool # 24 4 110

For loosening and tightening slotted nut on output drive flange. Used on 5HP24 and 5HP30. Use in conjunction with tool #24 1 220.

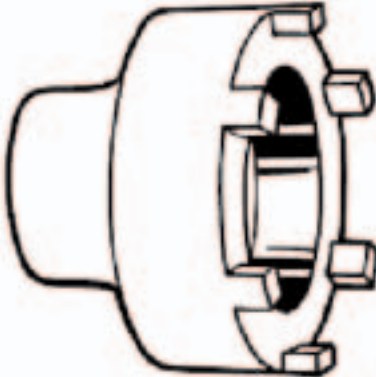

W 24 4 110

Tool # 24 1 220

Take up support for drive flange. Used when tightening of loosening slotted nut on output drive flange. Used with tool numbers 24 4 170 and 24 4 110.

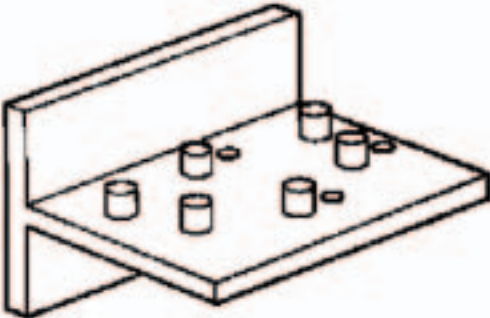

W24 1 220

Tool # 24 2 380

34 mm Socket used to tighten and loosen nut on output drive flange. Used with special tool 23 0 020. For GA6HP26Z transmission.



Tool # 24 2 310

Set of tools used to re-seal intermediate plate. Used on A4S310R and A4S270R. Tool Set Consists of:

1. 24 2 311 Pressure Plate
2. 24 2 312 Spindle with Pressure Plate
3. 24 2 313 Guide Pins (2)
4. 24 2 314 Slip Bushing

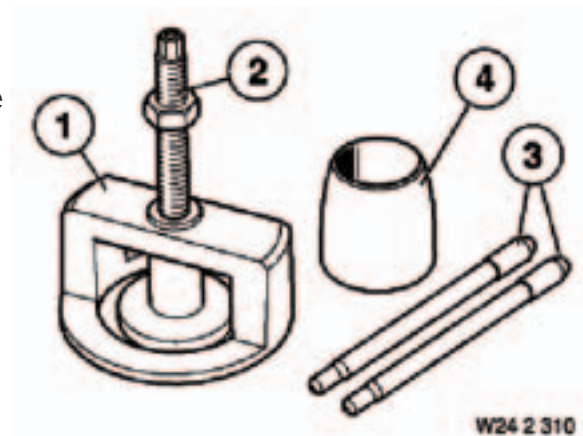

Tool # 24 1 200

Used to prevent damage to rotary shift shaft seal when fitting new seal on shift shaft. Used on A5S310Z (5HP18).



W24 1 200

Review Questions

1. The identification tag on the A5S440Z is located on _____
2. The 5HP19 transmission uses a _____ turbine speed sensor.
3. The transmission fluid temperature sensor is part of the _____ on the GA6HP26Z transmission.
4. On the GM5 transmission, the transmission range selector switch is located

5. EDS 1 is used for _____ on the 5HP24 transmission.
6. The "Warm up Phase Program" will be terminated if :

7. List the fluid types for the following transmissions:
A5S440Z _____ A5S560Z (late) _____
A5S360R _____ A5S325Z _____
GA6HP26Z _____ A5S310Z _____
8. Line pressure will be at _____ when there is no power to the pressure regulating solenoid.
9. What is the difference in Steptronic operation between a 2001 model year vehicle and a 2002 model year vehicle?

10. The "Curve Recognition" feature compares the _____
to inhibit _____ in a turn.

11. List 5 inputs to the TCM from the ECM over the CAN bus.

12. What SIB refers to "Transmission Fluid Checking Procedures"? _____

13. The Transmission will always default to the _____ Program when started.

14. List the transmissions which use a gradually applied TCC:

15. List 6 items that will occur during failsafe operation:
